

# Mini Excavators 1.2T to 5T

Earth Drill Models	X2000	X2500	3000 MAX	3500 MAX	4500 MAX
Part Number	21-20100	21-20200	21-33200	21-33300	21-33500
Excavator Machine Weight	1T to 2.5T	1.5 to 3T	2T to 4.5T	2.5T to 4.5T	3T to 4.5T
Torque	1886 Nm	2452 Nm	2900 Nm	3643 Nm	4535 Nm
Pressure	205 Bar	205 Bar	240 Bar	240 Bar	240 Bar
Oil Flow Range	25 to 57 l/m	27 to 65 l/m	27 to 75 l/m	40 to 75 l/m	50 to 95 l/m
Hydraulic Hoses	1/2" BSP	1/2" BSP	1/2" BSP	1/2" BSP	1/2" BSP
Output Shaft (STD)	65mm Rnd	65mm Rnd	65mm Rnd	65mm Rnd	65mm Rnd
Output Shaft (Optional)	2" Hex	2" Hex	2" Hex	2" Hex	2" Hex
Unit Weight	54kg	54kg	71kg	71kg	71kg
Unit Height	595mm	595mm	700mm	700mm	700mm
Unit Diameter	200mm	200mm	238mm	238mm	238mm
Auger Series	S4	S4	S4	S4	S4
Length	1.2M	1.2M	1.2M	1.2M	1.2M
Auger Diameter Range	100-400mm	100-500mm	100-600mm	100-750mm	100-900mm

SINGLE PIN HITCH

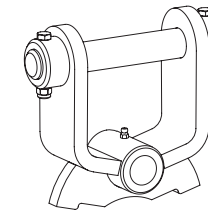

DOUBLE PIN HITCH

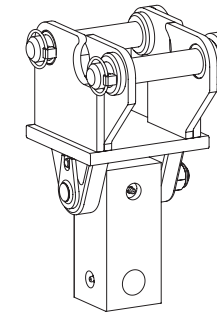

DOUBLE PIN CRADLE HITCH

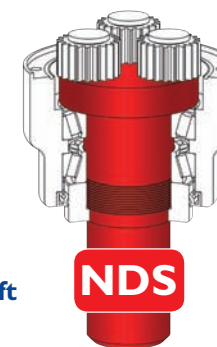
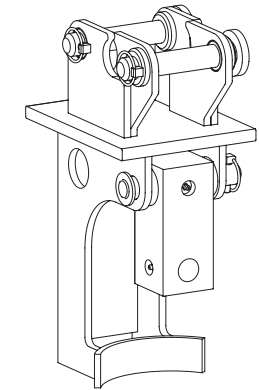

UNIQUE FEATURE  
Non Dislodgement Shaft

**NDS**

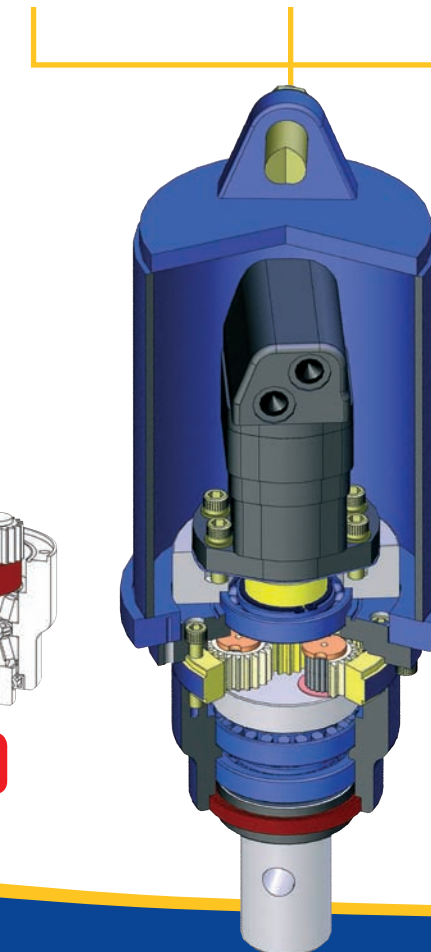

Cut away view  
of 3000 MAX  
Earth Drill